

Mechanical Grit Trap

MECHANICAL GRIT TRAP

OPERATING PRINCIPLE

Generally grit traps are designed hydraulically by reducing the velocity of flow in a suitable cross section to 30 cm/sec. Grit will then be directed to the bottom and organic substances will be kept in suspension.

In principle the Mechanical trap consists of a round basin with a floor sloping towards a central collecting sump. The contents of the basin are kept in motion by means of rotating paddles independent of the inflow, which is arranged to enter the tank tangentially.

Mineral solids settle to the centre collection sump, whereas lighter substances are kept in suspension and will eventually flow into the sewage works.

The retention time in the grit trap at maximum inflow and at maximum water level is designed to achieve separation of grit sized larger than 0.2 mm diameter.

Grit expulsion is achieved by means of an air lift pump built into the paddle mechanism. Prior to the extraction of grit the settled content is scoured with compressed air and washed with pressure water in the grit hopper. By this means reasonably clean grit is extracted.

SELECTION TABLE

TYPE	TANK DIA	INFLOW			
		L/SEC		M3/H	
		∇^1	∇^2	∇^1	∇^2
1-20	2.00	65-120		235-430	
2-25	2.50	110-210		400-760	
3-30	3.00	190-340		680-1220	
4-35	3.50	300-520		1080-1870	
5-42	4.20	520-880		1870-3160	
6-50	5.00	850-1400		3050-5000	
7-60	6.00	1400-2300		5000-8300	

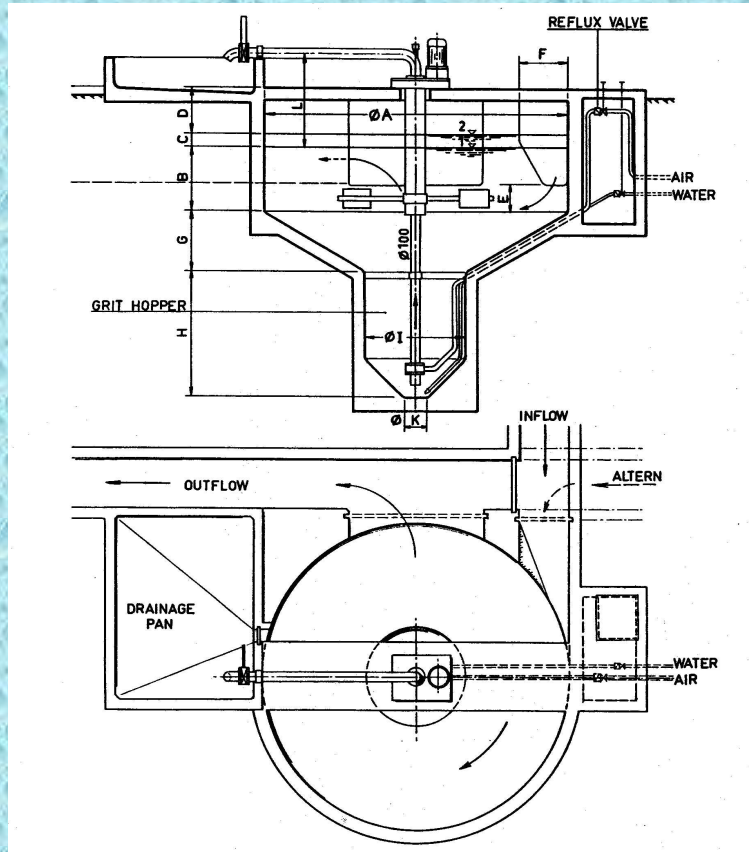

MECHANICAL GRIT TRAP

Selection Of A Typical Grit Trap

- ! The selection of a suitable trap is solely dependent on the maximum calculated inflow (See table above).
- ! The grit sump must be sized according to the quantity of grit expected (dimension H can be varied to suit).
- ! The grit trap does not require any hydraulic fall but it is, advantageous to position the outflow weir height approximately 5 cm below the inflow invert.
- ! The horizontal grit discharge pipe can be led to a drainage pan as shown in the diagram or it may be installed at a higher level so that it discharges directly into an open cart, waste bin or classifier. A deeper grit sump may be necessary to achieve the submergence ratio required to accomplish this.
- ! Dimensions A to L will be provided on request.